



## EVERFOCUS

### 1/3" 520TVL Color Flush Dome Camera Operation Instructions

Model No. **EFD300**

Please read this manual first for correct installation and operation. This manual should be retained for future reference. The information in this manual was current when published. The manufacturer reserves the right to revise and improve its products. All specifications are therefore subject to change without notice.

### **PRECAUTIONS**

**1. Do not install the camera near electric or magnetic fields.**

Install the camera away from TV, radio transmitter, magnet, electric motor, transformer, audio speakers since the magnetic fields generate from above devices will distort the video images.

**2. Never disassemble the camera nor put impurities in it.**

Disassembly or impurities may result in trouble or fire.

**3. Never face the camera toward the sun.**

Direct sunlight or severe ray may cause fatal damage to sensor and internal circuit.

**4. Keep the power cord away from water and liquid.**

Touching the wet power cord may result in electric shock.

**5. Never install the camera in areas exposed to water, oil or gas.**

Water, oil or gas may result in failure, electric shock or fire.

## **6. Cleaning**

Do not touch the surface of sensor by hand directly. Use a soft cloth to remove the dirt from the camera body. Use lens tissue or a cotton swab and ethanol to clean the sensor and the camera lens.

## **7. Do not operate the camera beyond the specified temperature, humidity or power source ratings.**

Use the camera at temperatures within 0°C ~ 50°C/32°F ~ 122°F and humidity between 20% ~ 80%. The input power source is 12VDC/24VAC.

## **PREFACE**

EFD300 High Resolution Flush Dome Camera Series are compact, full functioned CCD Color Cameras. The flush dome camera is designed with advanced digital processing circuitry for high resolution 1/3" color interline transfer CCD sensor, it has DIP switch for FL ON/OFF, Mirror ON/OFF, AGC ON/OFF and D/N ON/OFF. The dome camera uses a vari-focal auto iris lens for discreet surveillance or close-up viewing and it features with iris level volume control for the best viewing quality.

## **FEATURES**

- 1/3" SONY Super HAD color CCD pick up device for more than 520 TV lines of horizontal resolution
- The high sensitivity of 0.4Lux/F=1.2 is achieved by using 1/3" SONY Super HAD interline transfer color CCD
- The Electronic Shutter and AGC functions allow the camera to be used in environment with varying light levels
- Built-in Vari-Focal lens
- With manual PAN/TILT mechanism
- FL, Back Light Comp., AGC ON/OFF switchable
- Compact size: 135 mm O.D. x 112 mm H/5.4" O.D. x 4.4" H
- System available for NTSC or PAL

## SPECIFICATIONS

Pickup Device	1/3" SONY Super HAD CCD
Video Format	NTSC or PAL
Scanning System	NTSC: 525 TV lines, 60 fields/sec PAL: 625 TV lines, 50 fields/sec.
Picture Elements	768x494(NTSC) ; 752x582(PAL)
Horizontal Resolution	520TVL
Sensitivity	0.1Lux/F=1.2
S/N Ratio	Over 48dB (AGC off)
Electronic Shutter	1/50(1/60)~1/100,000
Lens Type	Vari-focal lens, Auto Iris f=4~9mm
Auto Gain Control	ON/OFF Switch
Flickerless	ON/OFF Switch
Back Light Comp.	ON/OFF Switch
Auto White Balance	Yes
Gamma Correction	0.45
Video Output	2 video outputs BNC 1.0Vp-p, 75ohm Additional testing video output 1.0Vp-p, 75ohm
Sync. Mode	Internal sync
Vandal Proof	Yes
Power Source	12VDC/24VAC
Power Consumption	12VDC: 2W max. 24VAC: 1.5W max.
Dimensions	135mm(O.D.) x 112mm(H); 5.4"(O.D.) x 4.4"(H)
Weight	0.7kg ; 1.6lbs
Operating Temperature	0°C~50°C ; 32°F~122°F (20%~80% Humidity)
Certifications	FCC/CE

## STANDARD ACCESSORIES

- Camera Unit
- Operation Instructions (this document)
- Drill Template

## OPTIONAL ACCESSORIES

- EN220 - 5.6-inch High Res LCD Field Monitor



## DIMENSION DIAGRAM

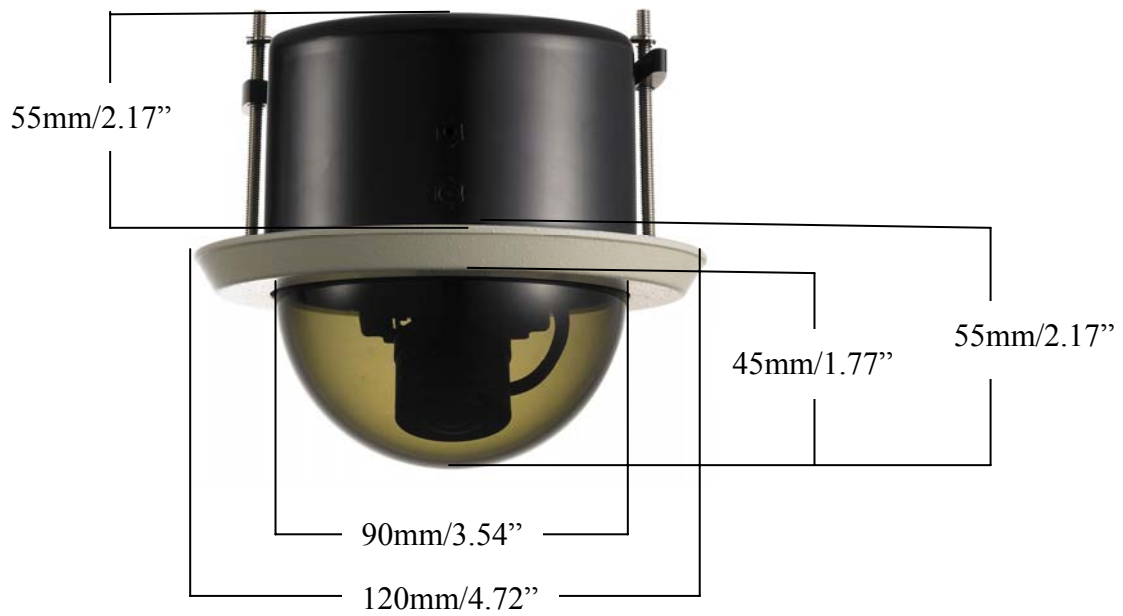

## HARDWARE OVERVIEW

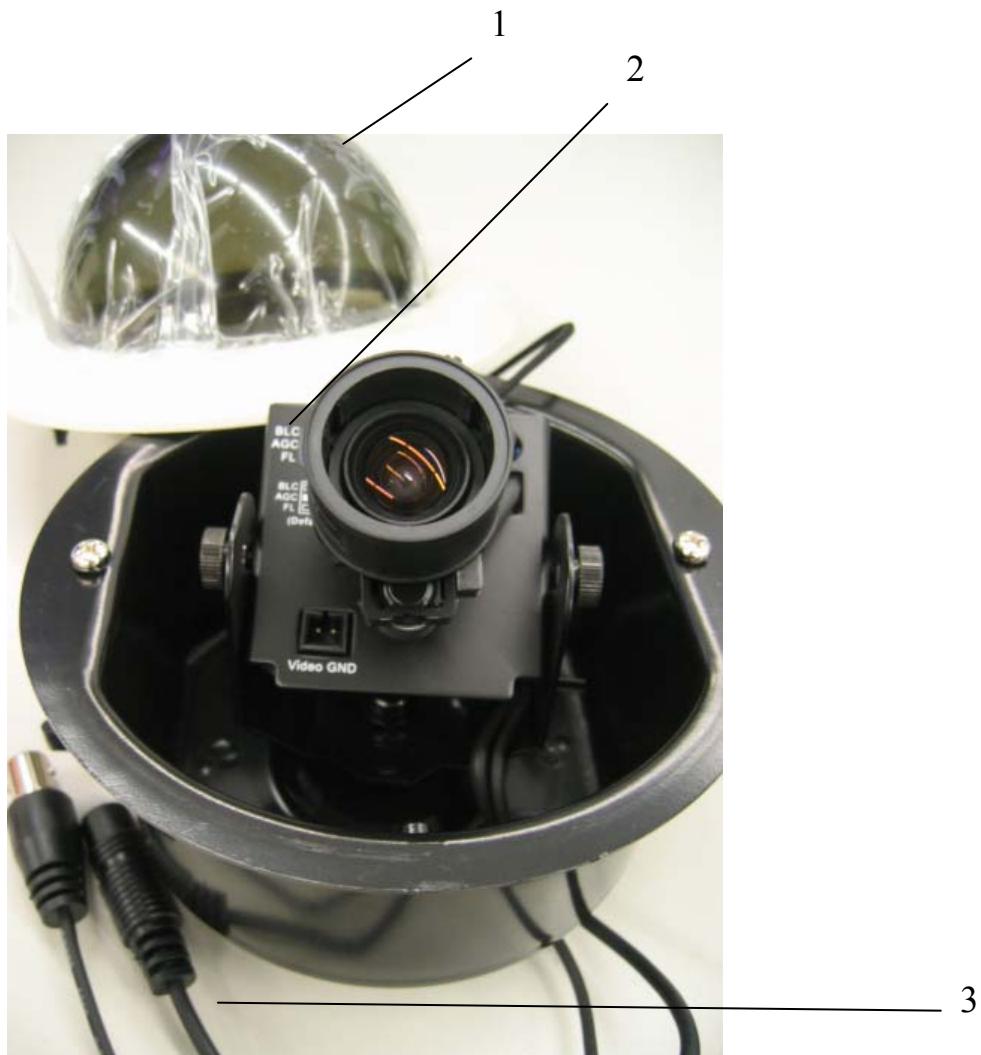

1. Camera Bubble Cover
2. Camera Setting- Please refer detail in camera setting for user manual.
3. BNC and Power Pigtail

## INSTALLATION

This section covers simple steps and detail installation. Please follow instruction for preventing any unnecessary damage.

### Simple Steps:

1. Cut a circle on the ceiling and mount the camera
2. Adjust lens, camera position
3. Adjust camera setting on Dip Switch

### Detail Steps:

#### 1. Cut a circle on the ceiling and mount the camera

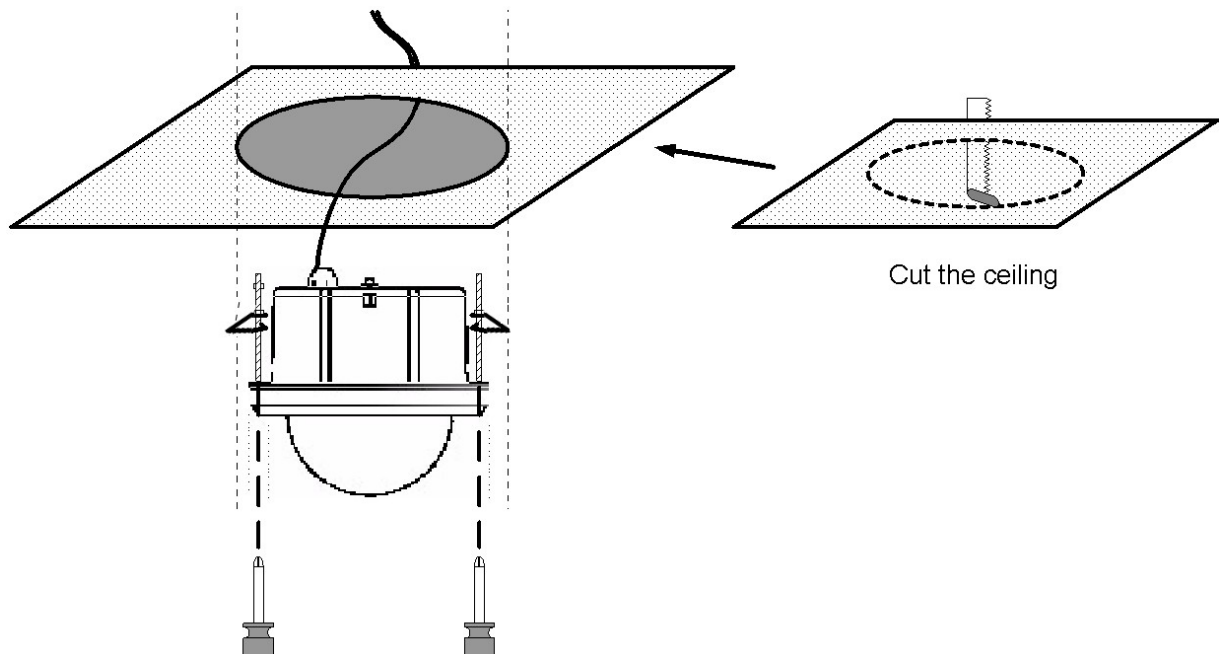

- a. Make a hole on the ceiling (110mm/4.33"φ) against the housing's shape by using **Drill Template** in the package.
- b. Mount camera into the hole that you just made.
- c. Connect Power and Video - Please connect 12VDC or 24VAC. Wrong power connection will cause power failure and shortage.
- d. Screw the bolts on both sides of housing by using a screwdriver until they are perfectly fit to the ceiling.
- e. Place the cover back and clip it on the camera.

## 2. Adjust lens, camera position

- a. **Optional connecting to testing monitor-** You can connect to testing monitor with video pin shown as following.

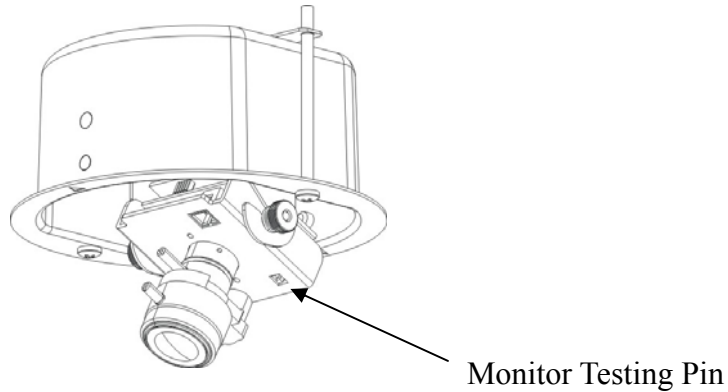

### b. Zoom and focus (for Vari-focal Lens Model)

(1) Loosen the zoom ring knob, and then turn the ring towards <W> or <T> as necessary to obtain the desired view range.

W side (Zoom out), the viewing range will be wider and the subject is smaller.

T side (Zoom in), the viewing range will be smaller and the subject is larger.

(2) Loosen the focus ring knob, then turn the ring towards < $\infty$ > or <N> as necessary to obtain clear video image.

(3) Repeat steps 1 and 2 until the best image is obtained.

Once the lens setting is finished, tighten the zoom ring and the focus ring knobs.

### c. Adjust View Angle

You can lose the camera fixing screw and tilt the camera to your best angle of view.

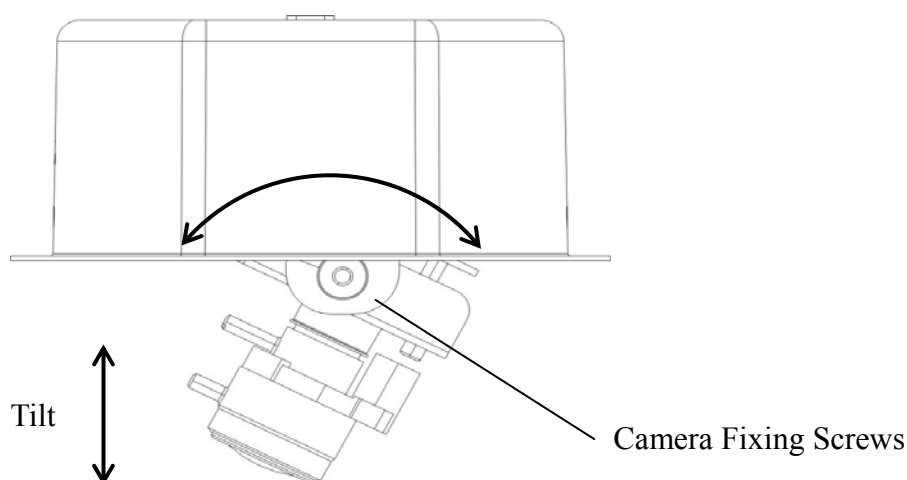

### 3. Camera Setting

#### CAMERA SETTING

##### ➤ BLC (Back Light Compensation)

When BLC is turned on, the AGC, FL and IRIS operating point is determined by averaging over the center area instead of entire field-of-view, so that a dimly-lit foreground object at center area can be clearly distinguished from brightly-lit backgrounds. BLC should not be used unless it is needed to compensate for back-light.

**The default setting is OFF.** For Auto-Iris lens model, the brightness can also be adjusted via the Iris level control VR.

##### ➤ AGC (Automatic Gain Control)

AGC ON: The sensitivity increases automatically when light is low.

AGC OFF: A low-noise picture is obtained under a low light condition.

**The default setting is ON.**

##### ➤ FL (Flickerless)

When picture flicker fiercely, turn FL on, then the camera will stabilize the speed of electronic shutter at 1/100(S)(NTSC) or 1/120(S)(PAL) automatically, and reduce the flicker immediately.

**The default setting is OFF.**

##### ➤ IRIS Level Control (For Vari-Focal Lens Model)

Brightness Level can be adjusted from the IRIS level VR while using the direct drive lens.

• Turn counterclockwise to L to get darker picture.

• Turn clockwise to H to get brighter picture. ➤ **Electronic Shutter (For Fixed Lens Model)**



ES ON: The camera continuously adjusts the shutter speed from 1/60 (NTSC), 1/50 (PAL) second to 1/100,000 second according to the luminance conditions of the scene.

ES OFF: The shutter speed is fixed at 1/60 (NTSC), 1/50 (PAL) second.

Set ES OFF, when auto iris lens is used or flicker is observed under a very bright fluorescent lamp. Otherwise, turn ES on for optimum performance.

# ***EverFocus Electronics Corp.***

## **Head Office:**

12F, No.79 Sec. 1 Shin-Tai Wu Road,  
Hsi-Chih, Taipei, Taiwan  
TEL: +886-2-26982334  
FAX: +886-2-26982380  
www.everfocus.com.tw

## **USA L.A. Office:**

1801 Highland Ave. Unit A  
Duarte, CA 91010, U.S.A.  
TEL: +1-626-844-8888  
FAX: +1-626-844-8838  
www.everfocus.com

## **USA N.Y. Office:**

415 Oser Avenue Unit S  
Hauppauge, NY 11788  
TEL: 631-436-5070  
FAX: 631-436-5027  
www.everfocus.com

## **Europe Office:**

Albert-Einstein-Strasse 1  
D-46446 Emmerich, Germany  
TEL: 49-2822-9394-0  
www.everfocus.de

## **China Office:**

Room B-05D-1, KESHI PLAZA , Shangdi  
Information Industry Base,  
Haidian District, Beijing China 100085  
TEL: +86-10-62973336/37/38/39  
FAX: +86-10-62971423  
www.everfocus.com.cn

## **Japan Office:**

1809 WBG MARIBU East 18F,  
2-6 Nakase.Mihama-ku.  
Chiba city 261-7118, Japan  
TEL: +81-43-212-8188  
FAX: +81-43-297-0081  
www.everfocus.com

	<p>Your EverFocus product is designed and manufactured with high quality materials and components which can be recycled and reused. This symbol means that electrical and electronic equipment, at their end-of-life, should be disposed of separately from your household waste. Please, dispose of this equipment at your local community waste collection/recycling centre. In the European Union there are separate collection systems for used electrical and electronic product. Please, help us to conserve the environment we live in!</p>	<p>Ihr EverFocus Produkt wurde entwickelt und hergestellt mit qualitativ hochwertigen Materialien und Komponenten, die recycelt und wieder verwendet werden können. Dieses Symbol bedeutet, dass elektrische und elektronische Geräte am Ende ihrer Nutzungsdauer vom Hausmüll getrennt entsorgt werden sollen. Bitte entsorgen Sie dieses Gerät bei Ihrer örtlichen kommunalen Sammelstelle oder im Recycling Centre. Helfen Sie uns bitte, die Umwelt zu erhalten, in der wir leben!</p>
---	--	--



P/N: MEFDG00400